

## GENERAL DESCRIPTION

The CM2865/A family is a positive voltage linear regulator developed utilizing CMOS technology featured low quiescent current (30 $\mu$ A typ.), low dropout voltage, and high output voltage accuracy. Built-in low on-resistance transistor provides low dropout voltage and large output current. A 1.0 $\mu$ F or greater can be used as an output capacitor.

The SOT-89 and SOT-223 packages are attractive for "Pocket" and "Hand Held" applications.

These robust devices are designed to prevent device failure under the worst operation condition with both Thermal Shutdown and Current Fold-back.

## FEATURES

- ◆ Very Low Dropout Voltage
- ◆ Low Current Consumption: Typ. 30 $\mu$ A, Max. 35 $\mu$ A
- ◆ High Accuracy Output Voltage: +/- 1.0%
- ◆ Guaranteed 350mA Output
- ◆ Thermal Shutdown
- ◆ Current Limiting
- ◆ Reverse battery protection
- ◆ Compact Package: SOT-89 and SOT-223
- ◆ Factory Pre-set Output Voltages
- ◆ Low Temperature Coefficient

## APPLICATIONS

- ◆ Battery-powered devices
- ◆ Personal communication devices
- ◆ Home electric/electronic appliances
- ◆ PC peripherals

## TYPICAL APPLICATIONS

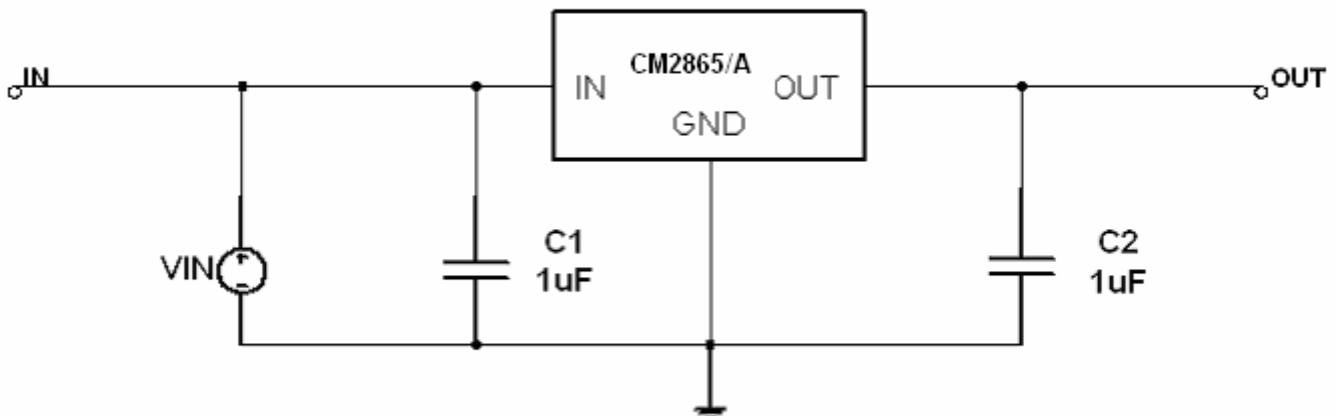

## PIN CONFIGURATION

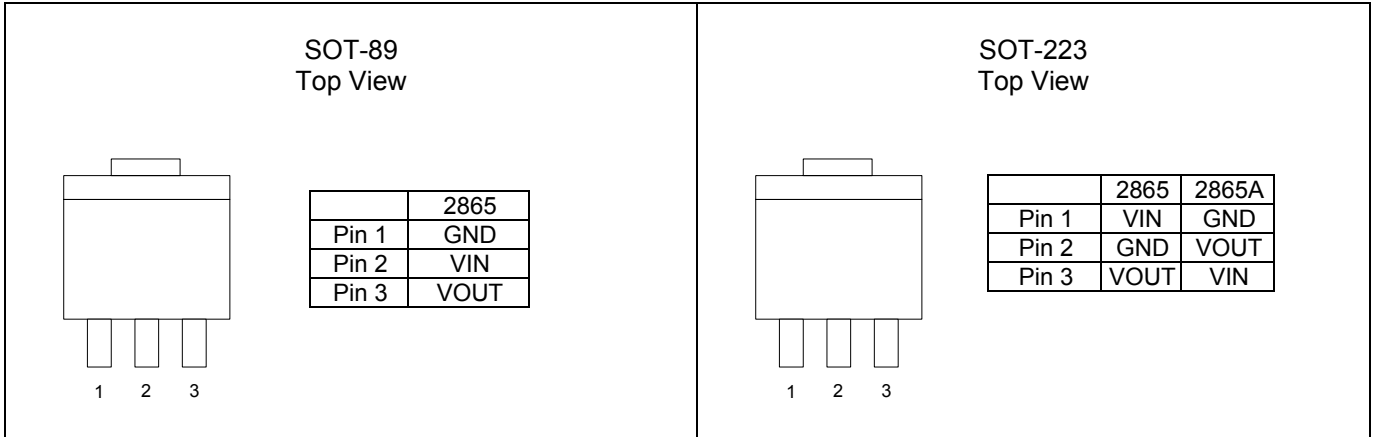

## BLOCK DIAGRAM

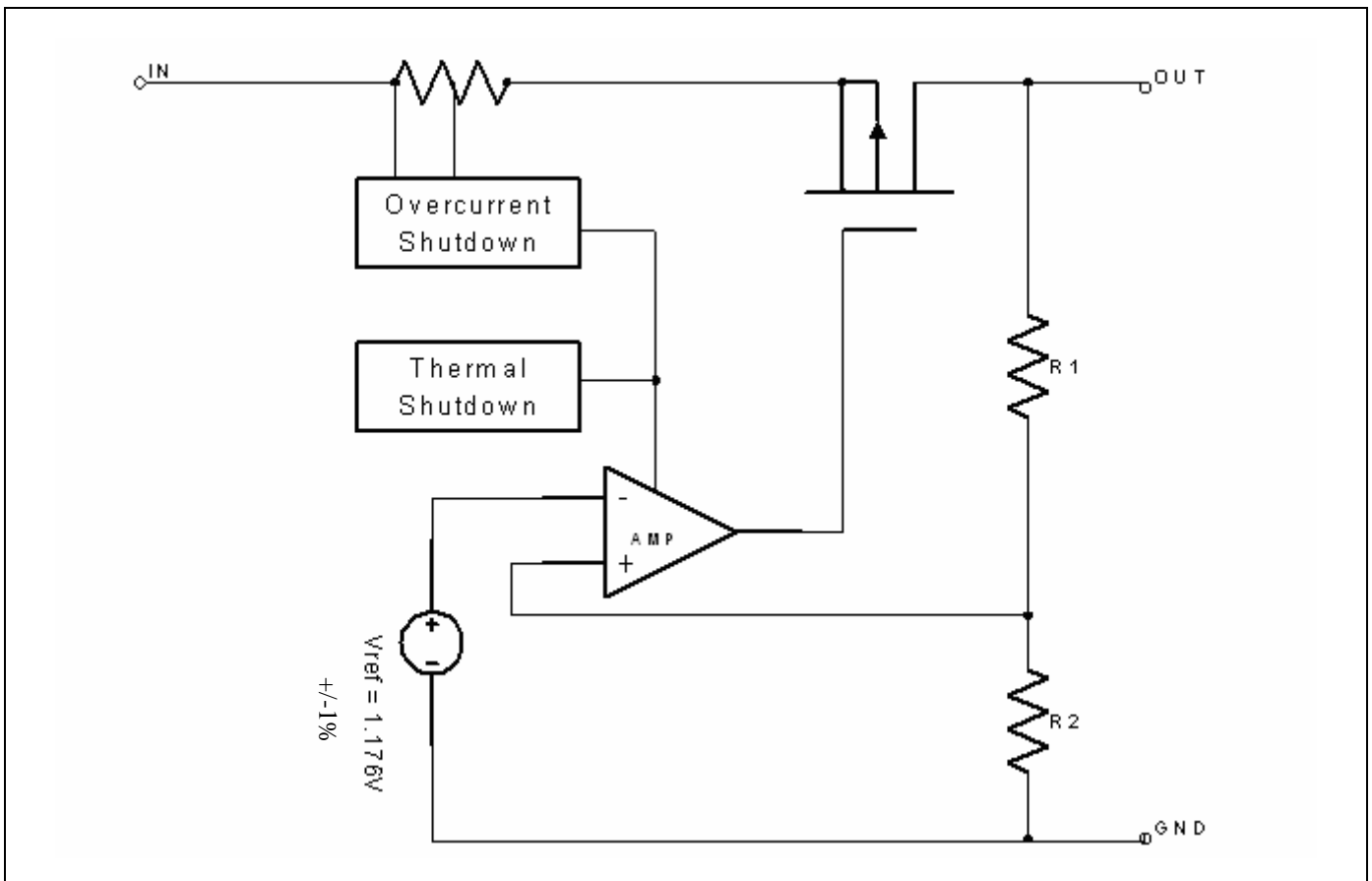



**CM2865(A)E5**  
**350mA CMOS LDO**  
**HIGH ACCURACY VOUT 1.0%**

**ORDERING INFORMATION**

Part Number	Output Voltage	Temperature Range	Package
CM2865E5IM89	1.95V	-40°C ~ +85°C	SOT-89
CM2865GE5IM89	1.95V	-40°C ~ +85°C	SOT-89
CM2865E5IM223	1.95V	-40°C ~ +85°C	SOT-223
CM2865GE5IM223	1.95V	-40°C ~ +85°C	SOT-223
CM2865AE5IM223	1.95V	-40°C ~ +85°C	SOT-223
CM2865AGE5IM223	1.95V	-40°C ~ +85°C	SOT-223

**Note:** For other pre-set output voltage, please contact Champion Sales office.

**ABSOLUTE MAXIMUM RATINGS**

Input Voltage ..... +7V  
 Output Current ..... 1A  
 Output Voltage ..... GND-0.3V to  $V_{IN}+0.3V$   
 ESD Classification ..... B

**OPERATING RATINGS**

Ambient Temperature Range ( $T_A$ ) ..... -40°C to +85°C  
 Junction Temperature Range ..... -40°C to +125°C

**THERMAL INFORMATION**

Parameter		Maximum	Unit
Thermal Resistance ( $\theta_{jc}$ )	SOT-89	100	°C/W
	SOT-223	50	
Thermal Resistance ( $\theta_{ja}$ )	SOT-89	180	°C/W
	SOT-223	100	
Internal Power Dissipation ( $P_D$ ) ( $\Delta T = 100^\circ C$ , No Heatsink)	SOT-89	400	mW
	SOT-223	900	
Maximum Junction Temperature		150	°C
Maximum Lead Temperature (10 Sec)		300	°C

Caution: Stress above the listed absolute rating may cause permanent damage to the device.

## ELECTRICAL CHARACTERISTICS

$T_A = +25^\circ\text{C}$ ;  $V_{IN} = V_{IN(MIN)}$  unless otherwise noted

Parameter	Symbol	Test Conditions	CM2865(A)E5			Unit
			Min.	Typ.	Max.	
Input Voltage	$V_{IN}$		Note 1		7	V
Output Voltage Accuracy	$V_{OUT}$	$I_O = 1\text{mA}$	-1.0		1.0	%
Dropout Voltage	$V_{DROPOUT}$	$I_O = 350\text{mA}$ , $V_{OUT} = V_{O(NOM)} - 1.5\%$	$1.5\text{V} < V_{O(NOM)} \leq 2.0\text{V}$		1000	mV
			$2.0\text{V} < V_{O(NOM)} \leq 2.8\text{V}$		800	
			$2.8\text{V} < V_{O(NOM)} < 3.8\text{V}$		660	mV
Output Current	$I_O$	$V_{OUT} > 1.2\text{V}$	350			mA
Current Limit	$I_{LIM}$	$V_{OUT} > 1.2\text{V}$ , $V_{IN} = V_{IN(MIN)}$	350	1000		mA
Short Circuit Current	$I_{SC}$	$V_{OUT} < 0.8\text{V}$		250		mA
Quiescent Current	$I_Q$	$I_O = 0\text{mA}$		30	50	$\mu\text{A}$
Ground Pin Current	$I_{GND}$	$I_O = 1\text{mA}$ to $350\text{mA}$		30	50	$\mu\text{A}$
Line Regulation	$REG_{LINE}$	$I_{OUT} = 5\text{mA}$ , $V_{IN} = V_{OUT} + 1$ to $V_{OUT} + 2$	$V_{OUT} \leq 2.0\text{V}$		0.15	%
			$V_{OUT} > 2.0\text{V}$		0.02	0.1
Load Regulation	$REG_{LOAD}$	$I_O = 1\text{mA}$ to $350\text{mA}$		0.2	1	%
Over Temperature Shutdown	OTS			175		$^\circ\text{C}$
Over Temperature Hysteresis	OTH			30		$^\circ\text{C}$
$V_{OUT}$ Temperature Coefficient	TC			30		ppm/ $^\circ\text{C}$
Power Supply Rejection	PSRR	$I_O = 100\text{mA}$ $C_O = 2.2\mu\text{F}$ ceramic	$f = 1\text{kHz}$		50	dB
			$f = 10\text{kHz}$		20	
			$f = 100\text{kHz}$		15	
Output Voltage Noise	eN	$f = 10\text{Hz}$ to $100\text{kHz}$ $I_O = 10\text{mA}$ , $C_{VBG} = 0\mu\text{F}$	$C_O = 2.2\mu\text{F}$		30	$\mu\text{V}_{rms}$
			$C_O = 100\mu\text{F}$		20	

**Note 1.**  $V_{IN(MIN)} = V_{OUT} + V_{DROPOUT}$

**Note 2.** As  $V_{IN}$  is larger than  $V_{IN(MIN)}$ , the Current Limit and output short current Spec value will increase

## DETAILED DESCRIPTION

The CM2865 family of CMOS regulators contain a PMOS pass transistor, voltage reference, error amplifier, over-current protection and thermal shutdown.

The P-channel pass transistor receives data from the error amplifier, over-current shutdown, and thermal protection circuits. During normal operation, the error amplifier compares the output voltage to a precision reference. Over-current and Thermal shutdown circuits become active when the junction temperature exceeds 175°C, or the current exceeds 350mA. During thermal shutdown, the output voltage remains low. Normal operation is restored when the junction temperature drops below 120°C.

## EXTERNAL CAPACITOR

The CM2865 is stable with an output capacitor to ground of 1.0µF or greater. It can keep stable even with higher or poor ESR capacitors. A second capacitor is recommended between the input and ground to stabilize VIN. The input capacitor should be larger than 0.1µF to have a beneficial effect. All capacitors should be placed in close proximity to the pins. A “quiet” ground termination is desirable.

## MARKING INFORMATION

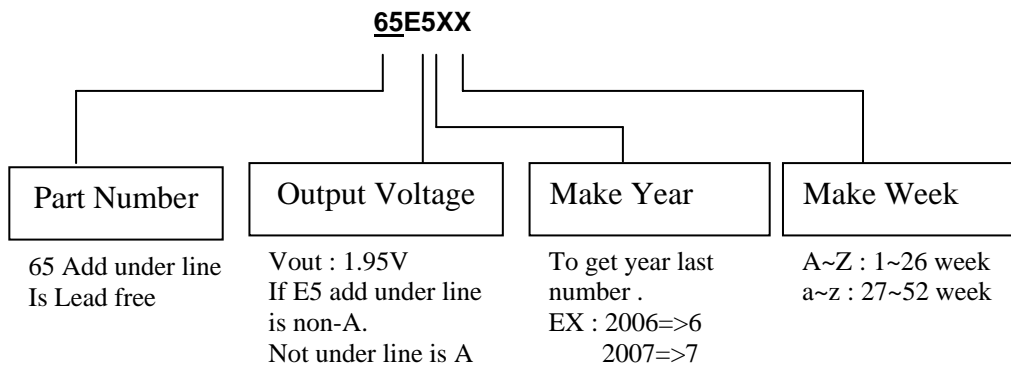

**TYPICAL ELECTRICAL CHARACTERISTICS**

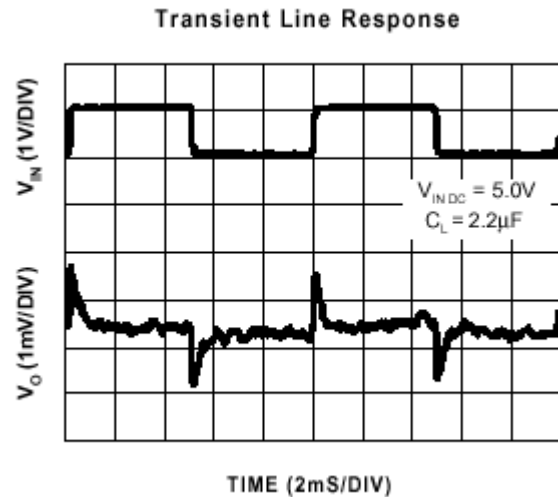
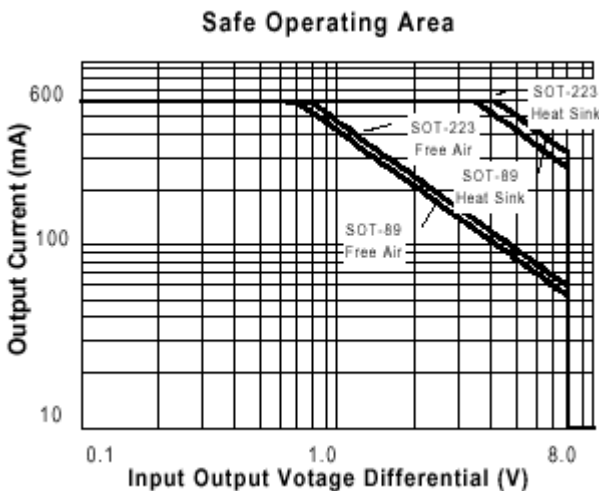
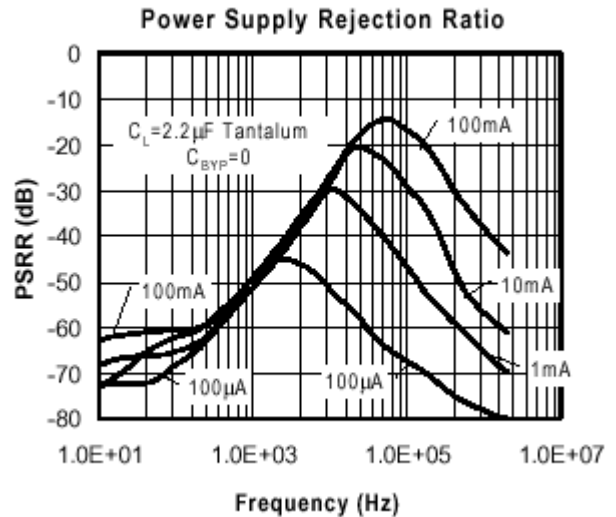
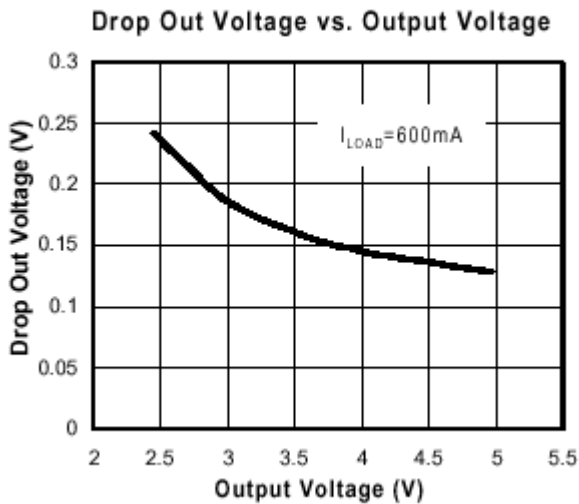
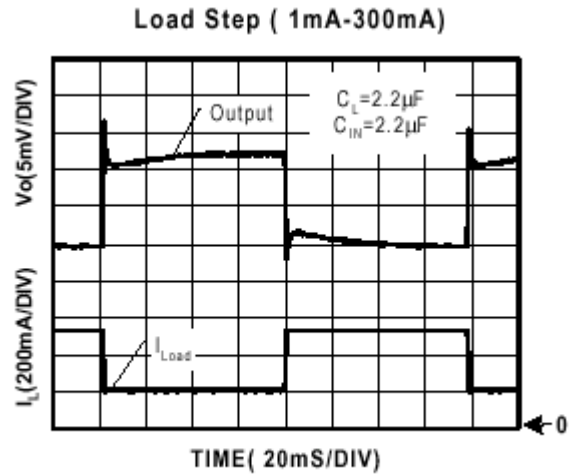
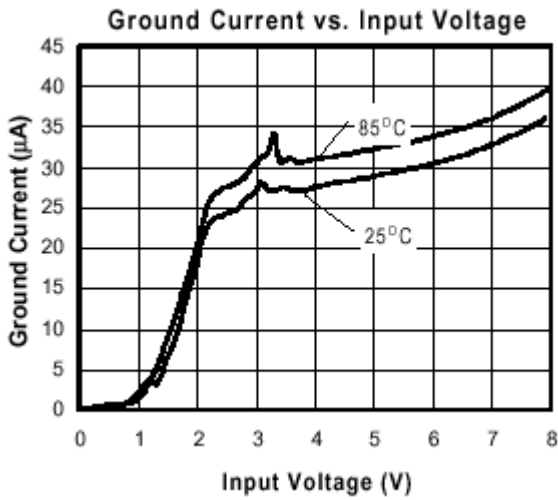

**Noise Measurement**

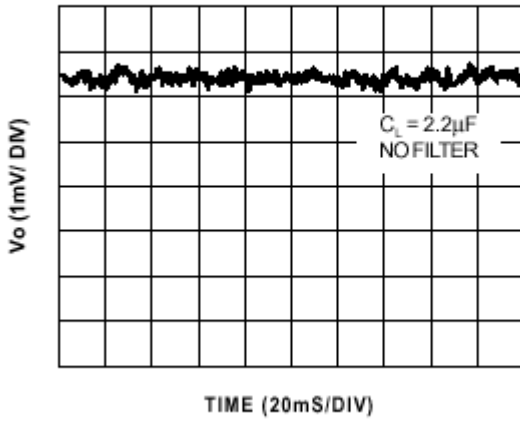

**Overtemperature Shutdown**

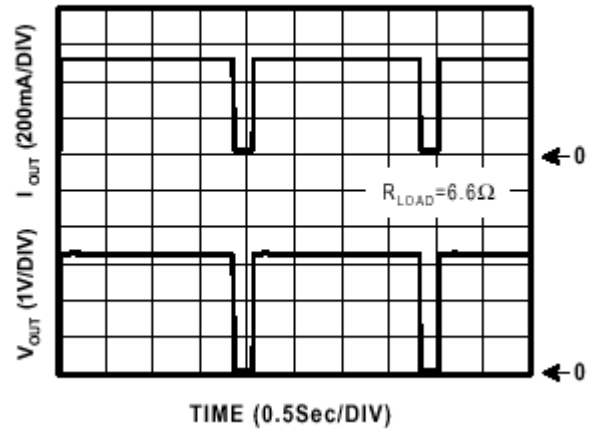

**Current Limit Response**

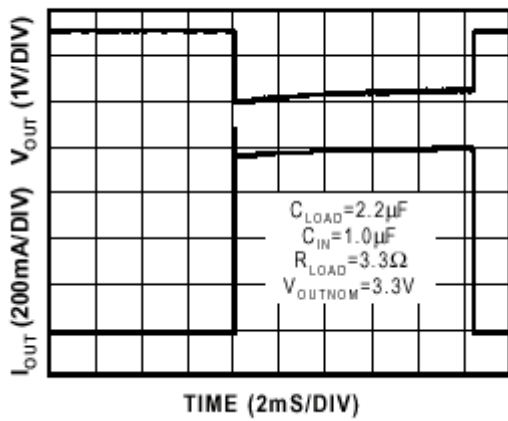

**Short Circuit Response**

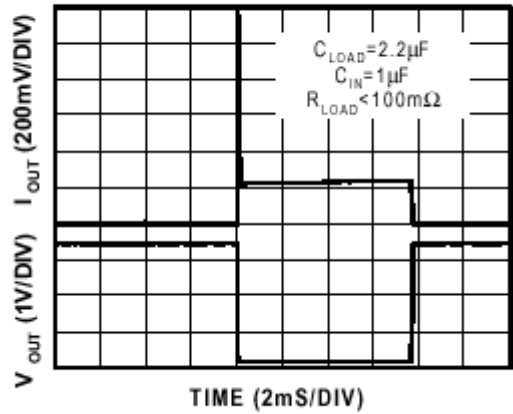

**PACKAGE DIMENSION**

**SOT-89 (M89)**

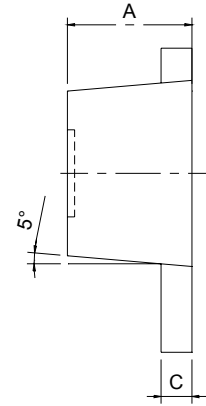
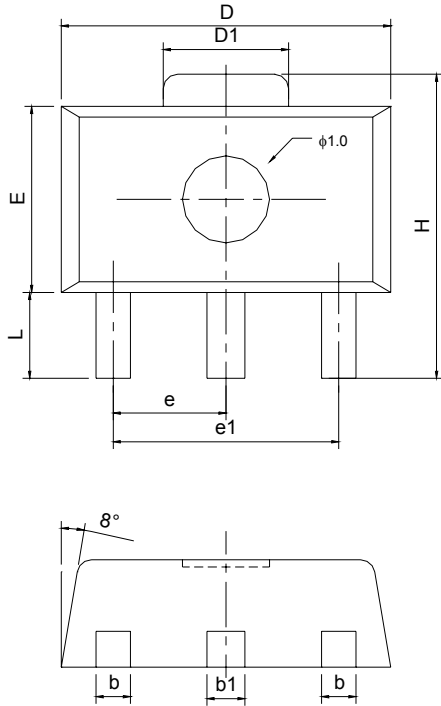

SYMBOLS	DIMENSIONS IN MILLIMETERS			DIMENSIONS IN INCHES		
	MIN	NOM	MAX	MIN	NOM	MAX
A	1.40	1.50	1.60	0.055	0.059	0.063
L	0.80	---	1.20	0.031	---	0.047
b	0.36	0.42	0.48	0.014	0.016	0.018
b1	0.41	0.47	0.53	0.016	0.018	0.020
C	0.38	0.40	0.43	0.014	0.015	0.017
D	4.40	4.50	4.60	0.173	0.177	0.181
D1	1.40	1.60	1.75	0.055	0.062	0.069
H	3.94	---	4.25	0.155	---	0.167
E	2.40	2.50	2.60	0.094	0.098	0.102
e1	2.90	3.00	3.10	0.114	0.118	0.122
e	1.45	1.60	1.55	0.067	0.069	0.061

**SOT-223 (M223)**

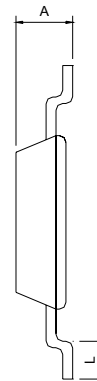
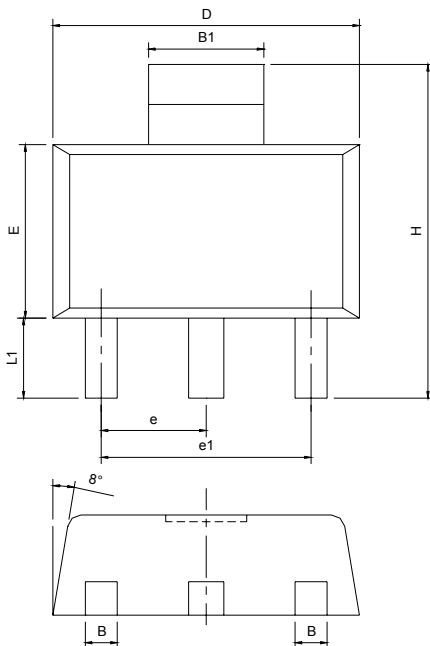

SYMBOLS	DIMENSIONS IN MILLIMETERS			DIMENSIONS IN INCHES		
	MIN	NOM	MAX	MIN	NOM	MAX
A	1.50	---	1.80	0.0591	---	0.0709
B	0.80	---	0.838	0.0313	---	0.033
B1	2.895	---	3.15	0.114	---	0.124
D	6.299	---	6.706	0.248	---	0.264
E	3.30	---	3.708	0.1299	---	0.146
e	---	2.30±0.05	---	---	0.0909±0.002	---
e1	---	4.80±0.05	---	---	0.1811±0.002	---
H	6.70	---	7.30	0.2638	---	0.2874
L	---	0.91MIN	---	---	0.036MIN	---
L1	---	2.00MAX	---	---	0.0787MAX	---
θ	---	---	13°	---	---	13°



## NUMBERING SCHEME

**Ordering Number:** CM2865(A)XXYZ (note1)

**Ordering Number:** CM2865(A)GXXYZGXYZ (note2)

**note1:**

CM2865(A)E5: 350mA CMOS LDO

XX : Suffix for voltage output (note 3)

Y : Suffix for Temperature Range (note 4)

Z : Suffix for Package Type (note 5)

**note2:**

CM2865(A)E5: 350mA CMOS LDO

G : Suffix for Pb Free Product

XX : Suffix for voltage output (note 3)

Y : Suffix for Temperature Range (note 4)

Z : Suffix for Package Type (note 5)

**note 3:** see CMOS LDO Voltage Suffix Table

**note 4:**

Y= I : -40°C~+85°C (only I grade support for all CMOS LDOs)

**note 5:**

Z is single alphabet with or without digits

M223 : SOT-223 (TR only)

M89 : SOT-89 (TR only)

**CMOS LDO Voltage Suffix Table**

Output Voltage	Suffix
1.95V	E5



## **IMPORTANT NOTICE**

Champion Microelectronic Corporation (CMC) reserves the right to make changes to its products or to discontinue any integrated circuit product or service without notice, and advises its customers to obtain the latest version of relevant information to verify, before placing orders, that the information being relied on is current.

A few applications using integrated circuit products may involve potential risks of death, personal injury, or severe property or environmental damage. CMC integrated circuit products are not designed, intended, authorized, or warranted to be suitable for use in life-support applications, devices or systems or other critical applications. Use of CMC products in such applications is understood to be fully at the risk of the customer. In order to minimize risks associated with the customer's applications, the customer should provide adequate design and operating safeguards.

### **HsinChu Headquarter**

---

5F, No. 11, Park Avenue II,  
Science-Based Industrial Park,  
HsinChu City, Taiwan  
TEL: +886-3-567 9979  
FAX: +886-3-567 9909

### **Sales & Marketing**

---

11F, No. 306-3, SEC. 1, Ta Tung Road,  
Hsichih, Taipei Hsien 221, Taiwan  
TEL: +886-2-8692 1591  
FAX: +886-2-8692 1596

---